

PEAD-A18AA8 & SUZ-KA18NAHZ
18,000 BTU/H HYPER-HEATING UNIVERSAL OUTDOOR UNIT
MID STATIC HORIZONTAL-DUCTED INDOOR UNIT



Job Name:

System Reference:

Date:



Indoor Unit.....PEAD-A18AA8

Outdoor Unit.....SUZ-KA18NAHZ

INDOOR UNIT FEATURES

- Unobtrusive ceiling-concealed design for short-run ductwork
- Wide ranging external static pressure (0.14-0.60 in. WG)
- Built-in condensate lift mechanism (up to 27-9/16")
- Auto fan speed mode
- Optional FB Series filter boxes for easy access and service
- Ideal for residential homes, retail shopping centers, larger classrooms, office complexes, conference rooms, ballrooms, fitness centers, and more
- Multiple control options available:
 - kumo cloud® smart device app for remote access
 - Third-party interface options
 - Wired or wireless controllers

OUTDOOR UNIT FEATURES

- The outdoor unit powers the indoor unit, and should a power outage occur, the system is automatically restarted when power returns
- INVERTER-driven compressor and LEV provide high efficiency and comfort while using only the energy needed to maintain maximum performance
- H2i® hyper heat performance offers 100% heating capacity at 5° F
- Hot-Start Technology: no cold air rush at equipment startup or when restarting after Defrost Cycle
- Quiet operation
- Blue Fin anti-corrosion treatment applied to the outdoor unit heat exchanger for increased coil protection and longer life
- Built-in base pan heater
- Innovative Joint Lap DC Motor leads to high efficiency and reliability
- Pulse Amplitude Modulation technology

SPECIFICATIONS: PEAD-A18AA8 & SUZ-KA18NAHZ

Cooling at 95°F ¹	Maximum Capacity	BTU/H	18,000
	Rated Capacity	BTU/H	18,000
	Minimum Capacity	BTU/H	9,320
	Maximum Power Input	W	1,400
	Rated Power Input	W	1,400
	Moisture Removal	Pints/h	3.6
	Sensible Heat Factor		0.78
Heating at 47°F ²	Maximum Capacity	BTU/H	28,000
	Rated Capacity	BTU/H	21,600
	Minimum Capacity	BTU/H	8,800
	Maximum Power Input	W	3,250
	Rated Power Input	W	1,890
	Power Factor [208V / 230V]	%	97.0 / 97.0
Heating at 17°F ³	Maximum Capacity	BTU/H	21,600
	Rated Capacity	BTU/H	14,200
	Maximum Power Input	W	2,550
	Rated Power Input	W	1,670
Heating at 5°F ⁴	Maximum Capacity	BTU/H	21,600
Maximum Power Input	W	3,800	
Heating at -4°F ⁵	Maximum Capacity	BTU/H	19,000
Heating at -13°F ⁷	Maximum Capacity	BTU/H	18,000
Efficiency	SEER SEER2		18.9 18.3
	EER ¹ EER2 ¹		12.8 12.0
	HSPF [IV] HSPF2 [IV]		10.8 9.2
	COP at 47°F ²		3.3
	COP at 17°F at Maximum Capacity ³		2.4
	COP at 5°F at Maximum Capacity ⁴		1.66
	ENERGY STAR® Certified		Yes
Electrical	Voltage, Phase, Frequency		208/230, 1, 60
	Guaranteed Voltage Range	V AC	187 - 253
	Voltage: Indoor - Outdoor, S1-S2	V AC	208/230
	Voltage: Indoor - Outdoor, S2-S3	V DC	24
	Short-circuit Current Rating [SCCR]	kA	5
	Recommended Fuse/Breaker Size (Outdoor)	A	20
	Recommended Wire Size [Indoor - Outdoor]	AWG	14
Power Supply		Indoor unit is powered by the outdoor unit	
Indoor Unit	MCA	A	2.44
	Fan Motor Full Load Amperage	A	1.95
	Fan Motor Output	W	121
	Fan Motor Type		DC Motor
	Airflow Rate at Cooling, Dry	CFM	424–512–600
	Airflow Rate at Cooling, Wet	CFM	382–461–540
	Airflow Rate at Heating, Dry	CFM	424–512–600
	Sound Pressure Level [Cooling]	dB[A]	29–34–37
	Sound Pressure Level [Heating]	dB[A]	29–34–37
	External Static Pressure	in.WG	0.14–0.2–0.28–0.4–0.6
	Drain Pipe Size	In. [mm]	1-1/4 [32]
	Condensate Lift Mechanism, Maximum Distance	In. [mm]	27-9/16 [700]
	Coating on Heat Exchanger		—
	External Finish Color		Galvanized
	Unit Dimensions	W x D x H: In. [mm]	35-7/16 x 28-7/8 x 9-7/8 [900 x 732 x 250]
	Package Dimensions	W x D x H: In. [mm]	46-1/16 x 35-7/16 x 13 [1,170 x 900 x 330]
	Unit Weight	Lbs. [kg]	60 [27]
Package Weight	Lbs. [kg]	71 [32]	
Indoor Unit Operating Temperature Range	Cooling Intake Air Temp [Maximum / Minimum]*	°F	90 DB, 72 WB / 66 DB, 61 WB
	Heating Intake Air Temp [Maximum / Minimum]	°F	77 DB / 59 DB

NOTES:

AHRI Rated Conditions

(Rated data is determined at a fixed compressor speed)

¹Cooling (Indoor // Outdoor)

°F 80 DB, 67 WB // 95 DB, 75 WB

²Heating at 47°F (Indoor // Outdoor)

°F 70 DB, 60 WB // 47 DB, 43 WB

³Heating at 17°F (Indoor // Outdoor)

°F 70 DB, 60 WB // 17 DB, 15 WB

Conditions

⁴Heating at 5°F (Indoor // Outdoor)

°F 70 DB, 60 WB // 5 DB, 4 WB

⁵Heating at -4°F (Indoor // Outdoor)

°F 70 DB, 60 WB // -4 DB, -5 WB

⁷Heating at -13°F (Indoor // Outdoor)

°F 70 DB, 60 WB // -13 DB, -14 WB

*Indoor/Outdoor Unit Operating Temperature Range (Cooling Air Temp [Maximum / Minimum]):

• Applications should be restricted to comfort cooling only; equipment cooling applications are not recommended for low ambient temperature conditions.

**Outdoor Unit Operating Temperature Range (Cooling Thermal Lock-out / Re-start Temperatures; Heating Thermal Lock-out / Re-start Temperatures):

• System cuts out in heating mode to avoid thermistor error and automatically restarts at these temperatures.

SPECIFICATIONS: PEAD-A18AA8 & SUZ-KA18NAHZ

Outdoor Unit	MCA	A	17.0	
	MOCP	A	31	
	Fan Motor Full Load Amperage	A	1	
	Fan Motor Output	W	60	
	Airflow Rate [Cooling / Heating]	CFM	2,020 / 1,930	
	Refrigerant Control		LEV	
	Defrost Method		Reverse Cycle	
	Coating on Heat Exchanger		Blue Fin Coating	
	Sound Pressure Level, Cooling ¹	dB(A)	55	
	Sound Pressure Level, Heating ²	dB(A)	55	
	Compressor Type		DC INVERTER-driven Twin Rotary	
	Compressor Model		SNB220FQGMT	
	Compressor Rated Load Amps	A	13	
	Compressor Locked Rotor Amps	A	16.0	
	Compressor Oil [Type // Charge]	oz.	FV50S // 23.7	
	External Finish Color		Ivory Munsell 3Y 7.8/1.1	
	Base Pan Heater		Built-in	
	Unit Dimensions	W x D x H: In. [mm]	33-1/16 x 13 x 34-5/8 [840 x 330 x 880]	
	Package Dimensions	W x D x H: In. [mm]	38-3/4 x 16-3/4 x 39 [980 x 420 x 990]	
	Unit Weight	Lbs. [kg]	131 [59.5]	
	Package Weight	Lbs. [kg]	150 [68]	
	Outdoor Unit Operating Temperature Range	Cooling Air Temp [Maximum / Minimum]*	°F	115 DB / 14 DB
		Cooling Thermal Lock-out / Re-start Temperatures**	°F	-1 / 3
Heating Air Temp [Maximum / Minimum]		°F	75 DB, 65 WB / -13 DB, -14 WB	
Heating Thermal Lock-out / Re-start Temperatures**		°F	-25 / -14	
Refrigerant	Type		R410A	
	Pre-Charged Refrigerant Amount	Lbs, oz	3.0, 12.0	
	Maximum Pre-Charged Piping Length	Ft. [m]	100.0 [30.0]	
	Additional Refrigerant Charge Per Additional Piping Length	oz./Ft. [g/m]	0 [0]	
Piping	Gas Pipe Size O.D. [Flared]	In.[mm]	1/2 [12.7]	
	Liquid Pipe Size O.D. [Flared]	In.[mm]	1/4 [6.35]	
	Maximum Piping Length	Ft. [m]	100 [30]	
	Maximum Height Difference	Ft. [m]	50 [15]	
	Maximum Number of Bends		10	

NOTES:

AHRI Rated Conditions

(Rated data is determined at a fixed compressor speed)

¹ Cooling (Indoor // Outdoor)	°F	80 DB, 67 WB // 95 DB, 75 WB
² Heating at 47°F (Indoor // Outdoor)	°F	70 DB, 60 WB // 47 DB, 43 WB
³ Heating at 17°F (Indoor // Outdoor)	°F	70 DB, 60 WB // 17 DB, 15 WB

Conditions

⁴ Heating at 5°F (Indoor // Outdoor)	°F	70 DB, 60 WB // 5 DB, 4 WB
⁵ Heating at -4°F (Indoor // Outdoor)	°F	70 DB, 60 WB // -4 DB, -5 WB
⁷ Heating at -13°F (Indoor // Outdoor)	°F	70 DB, 60 WB // -13 DB, -14 WB

*Indoor/Outdoor Unit Operating Temperature Range (Cooling Air Temp [Maximum / Minimum]):

- Applications should be restricted to comfort cooling only; equipment cooling applications are not recommended for low ambient temperature conditions.

**Outdoor Unit Operating Temperature Range (Cooling Thermal Lock-out / Re-start Temperatures; Heating Thermal Lock-out / Re-start Temperatures):

- System cuts out in heating mode to avoid thermistor error and automatically restarts at these temperatures.

INDOOR UNIT ACCESSORIES: PEAD-A18AA8

Control Interface	3-Pin Connector	PAC-715AD
	Airzone ZBS Wired Blueface Principal Controller White	AZZBSBLUEFACECB
	Airzone ZBS Wired Blueface Principal Controller White	AZZBSBLUEZEROCB
	Airzone ZBS Wired Lite Controller White	AZZBSLITECB
	Airzone ZBS Wireless Lite Controller White	AZZBSLITERB
	Airzone ZBS Wireless Think Controller White	AZZBSTHINKRB
	BACnet® and Modbus® Interface	PAC-UKPRC001-CN-1
	CN24 Relay Kit	CN24RELAY-KIT-CM3
	IT Extender	PAC-WHS01IE-E
	kumo station® for kumo cloud®	PAC-WHS01HC-E
	Remote Operation Adapter†	PAC-SF40RM-E
	Thermostat Interface	PAC-US444CN-1
	Thermostat Interface	PAC-US445CN-1
	USNAP Adapter	PAC-WHS01UP-E
Remote Sensor	Wireless Interface for kumo cloud®	PAC-USWHS002-WF-2
	Flush Mount Remote Temperature Sensor	PAC-USSEN002-FM-1
	Flush Mount Temperature Sensor	PAC-USSEN001-FM-1
	Remote Temperature Sensor	PAC-SE41TS-E
Wired Remote Controller	Wireless temperature and humidity sensor for kumo cloud®	PAC-USWHS003-TH-1
	Deluxe Wired MA Remote Controller†	PAR-40MAAU
	Simple Ductless Wired Remote Controller	PAC-SDW01RC-1
	Simple MA Remote Controller†	PAC-YT53CRAU-J
Wireless Remote Controller	Touch MA Controller†	PAR-CT01MAU-SB
	kumo touch™ RedLINK™ Wireless Controller	MHK2
	Lockdown bracket for remote controller	RCMKP1CB
	Wireless MA Receiver	PAR-FA32MA-W
Condensate	Wireless MA Remote Controller	PAR-FL32MA-E
	Blue Diamond (Advanced) Mini Condensate Pump w/ Reservoir & Sensor (208/230V) [recommended]	X87-721
	Blue Diamond (MegaBlue Advanced) Condensate Pump w/ Reservoir & Sensor	X87-835
	Blue Diamond Sensor Extension Cable — 15 Ft.	C13-103
Control Wire	Refco Condensate Pump (100-240 VAC) up to 120,000 BTU/H	COMBI
	20/2PR, 1PR shielded + 1PR plenum wire for Airzone, 100 ft reel	CW2042S2-100
Disconnect Switch	20/2PR, shielded + 1PR plenum wire for Airzone, 500 ft reel	CW2042S2-500
	(30A/600V/UL) [fits 2" X 4" utility box] - Black	TAZ-MS303
Filter Box	(30A/600V/UL) [fits 2" X 4" utility box] - White	TAZ-MS303W
	Filter Box with MERV 13 Filter	FBM2-2-A
Lineset	100' x 1/4" x 100' / 1/2" Lineset (Twin-Tube Insulation)	MLS141212T-100
	15' x 1/4" x 15' / 1/2" Lineset (Twin-Tube Insulation)	MLS141212T-15
	30' x 1/4" x 30' / 1/2" Lineset (Twin-Tube Insulation)	MLS141212T-30
	50' x 1/4" x 50' / 1/2" Lineset (Twin-Tube Insulation)	MLS141212T-50
	65' x 1/4" x 65' / 1/2" Lineset (Twin-Tube Insulation)	MLS141212T-65

NOTES:

†PAC-SF40RM-E (Unable to use with wireless remote controller)

OUTDOOR UNIT ACCESSORIES: SUZ-KA18NAHZ

Air Outlet Guide	Air Outlet Guide	MAC-886SG-E
Control/Service Tool	M- & P-Series Maintenance Tool Cable Set	M21EC0397
Mini-Split Wire	14 Gauge, 4 wire MiniSplit Cable—250 ft. roll	S144-250
	14 Gauge, 4 wire MiniSplit Cable—250 ft. roll	SW144-250
	14 Gauge, 4 wire MiniSplit Cable—50 ft. roll	S144-50
	14 Gauge, 4 wire MiniSplit Cable—50 ft. roll	SW144-50
	16 Gauge, 4 wire MiniSplit Cable—250 ft. roll	S164-250
	16 Gauge, 4 wire MiniSplit Cable—250 ft. roll	SW164-250
	16 Gauge, 4 wire MiniSplit Cable—50 ft. roll	S164-50
	16 Gauge, 4 wire MiniSplit Cable—50 ft. roll	SW164-50
Mounting Pad	Condensing Unit Mounting Pad: 16" x 36" x 3"	ULTRILITE1
Optional Defrost Heater	Base Heater	MAC-642BH-U1
Stand	18" Single Fan Stand	QSMS1801M
	24" Single Fan Stand	QSMS2401M
	Condenser Wall Bracket	QSWB2000M-1
	Outdoor Unit Stand — 12" High	QSMS1201M

INDOOR UNIT DIMENSIONS: PEAD-A18AA8

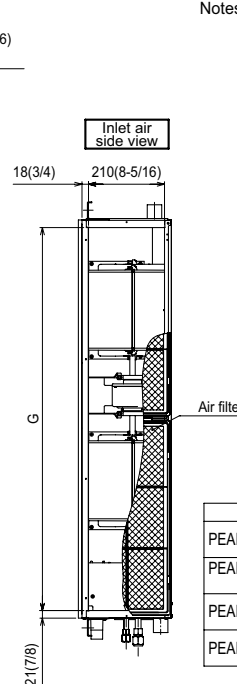
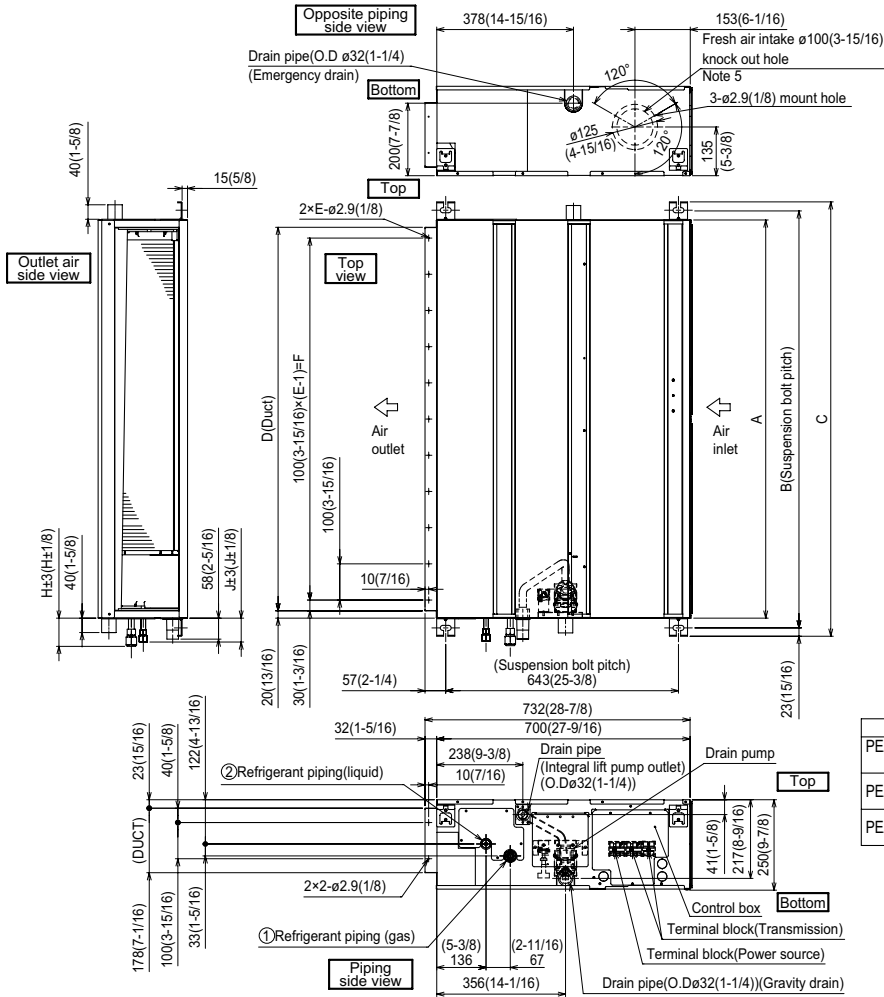

- Notes
1. Use an M10 screw for the suspension bolt (field supply).
 2. Keep the service space for maintenance at the bottom.
 3. This drawing is for PEAD-A09-12-15-18-24-30AA8 models, which have 2 fans. PEAD-A36AA8 model has 3 fans.
 4. If the inlet duct is used, remove the air filter (supplied with the unit), then install the filter (field supply) at the suction side.
 5. Heat air to $0^\circ\text{C}(32^\circ\text{F})$ or higher when taking fresh air with a fresh air intake.

Unit:mm(in.)

Model	J	①Gas pipe	②Liquid pipe
PEAD-A09AA8	62 (2-1/2)	$\phi 9.52$ (3/8)	$\phi 6.35$ (1/4)
PEAD-A12,15,18AA8	62 (2-1/2)	$\phi 12.7$ (1/2)	$\phi 6.35$ (1/4)
PEAD-A24,30AA8	66 (2-5/8)	$\phi 15.88$ (5/8)	$\phi 9.52$ (3/8)
PEAD-A36AA8			

Unit:mm(in.)

Model	A	B	C	D	E	F	G	H
PEAD-A09,12,15,18AA8	900 (35-7/16)	954 (37-9/16)	1000 (39-3/8)	860 (33-7/8)	9	800 (31-1/2)	858 (33-13/16)	72 (2-7/8)
PEAD-A24,30AA8	1100 (43-5/16)	1154 (45-7/16)	1200 (47-1/4)	1060 (41-3/4)	11	1000 (39-3/8)	1058 (41-11/16)	78 (3-1/8)
PEAD-A36AA8	1400 (55-1/8)	1454 (57-1/4)	1500 (59-1/16)	1360 (53-9/16)	14	1300 (51-3/16)	1358 (53-1/2)	

OUTDOOR UNIT DIMENSIONS: SUZ-KA18NAHZ

Unit: inch

REQUIRED SPACE

*1 20 in. (500 mm) or more when front and sides of the unit are clear

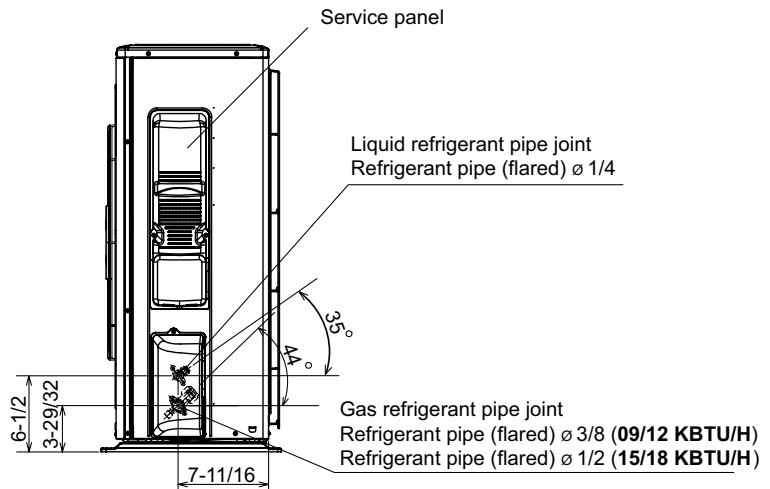
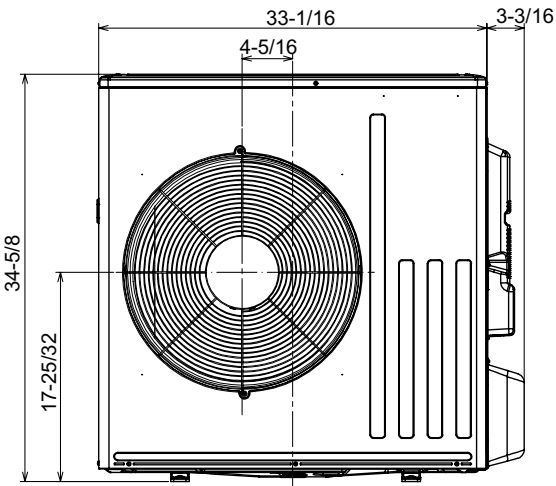
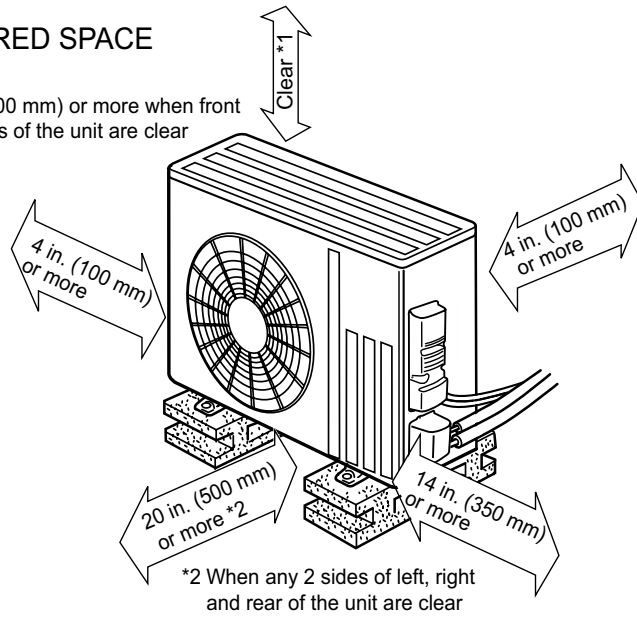
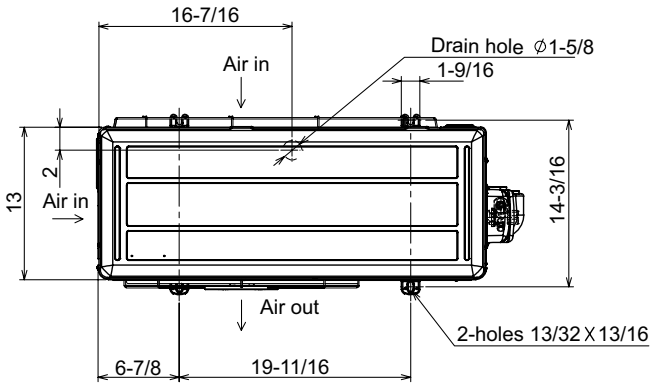

1340 Satellite Boulevard Suwanee, GA 30024
Toll Free: 800-433-4822 www.mehvac.com

FORM# PEAD-A18AA8 & SUZ-KA18NAHZ - 202304

